

FETA7000T

FET A 7000 T -

① ② ③ ④ ⑤

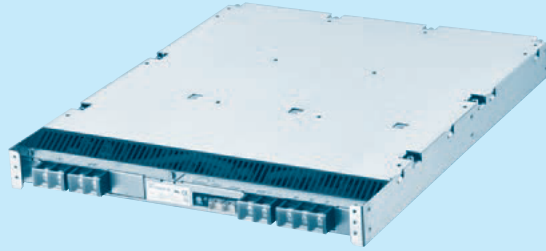

Example recommended EMI/EMC filter
TAC-30-683



*A higher current rating EMI/EMC filter may be recommended in view of the other devices that could be connected in parallel with the power supply.

- ① Series name
- ② Single output
- ③ Output wattage
- ④ Triple input phase
- ⑤ Output voltage

*Make sure necessary tests will be carried out on your end equipment with the power supply installed in accordance with any required EMC/EMI regulations.

MODEL	FETA7000T-48	FETA7000T-144
MAX OUTPUT WATTAGE[W]	*1 7113	7488
DC OUTPUT	48V 148.2A	144V 52A

SPECIFICATIONS

	MODEL	FETA7000T-48	FETA7000T-144	
INPUT	VOLTAGE[V]	AC170 - 264 3 φ (Output derating is required at AC170V - 180V. Refer to instruction manual 4.2)		
	CURRENT[A]	ACIN 200V	22.7typ	
	FREQUENCY[Hz]		50 / 60 (47 - 63)	
	EFFICIENCY[%]	ACIN 230V	90.5% (Io=100%)	
	POWER FACTOR	ACIN 230V	0.98typ (Io=100%)	
	INRUSH CURRENT[A]	ACIN 200V *2	30max / 60max (Primary inrush current / Secondary inrush current) (More than 10 sec. to re-start)	
	LEAKAGE CURRENT[mA]		3.0max (ACIN 240V 60Hz, Io=100%, According to IEC60950-1)	
OUTPUT	VOLTAGE[V]	48	144	
	CURRENT[A]	ACIN 170V-180V ACIN 180V-264V	Output derating is required at ACIN 180V or less (refer to instruction manual 4.2) 148.2	
	LINE REGULATION[mV]		192max	
	LOAD REGULATION[mV]		960max	
	RIPPLE[mVp-p]	0 to +40°C *3	360max	720max
		-10 to 0°C *3	480max	960max
	RIPPLE NOISE[mVp-p]	0 to +40°C *3	480max	960max
		-10 to 0°C *3	600max	1200max
	TEMPERATURE REGULATION[mV]	0 to +40°C	480max	2200max
		-10 to +40°C	600max	2800max
	DRIFT[mV]	*4	192max	384max
	START-UP TIME[s]		1.7max (ACIN 200V, Io=100%)	
	HOLD-UP TIME[ms]	ACIN 200V	10typ (Io=100%) 20typ (Io=50%)	
OUTPUT VOLTAGE ADJUSTMENT RANGE[V] *5		28.8 - 52.8 *6	86.4 - 158.4 *7	
OUTPUT VOLTAGE SETTING[V]		47 - 49		
PROTECTION CIRCUIT AND OTHERS	OVERCURRENT PROTECTION	Works over 105% of rating (Recovers automatically, Intermittent overcurrent) (Output voltage shuts down when the output voltage continuously drops due to overcurrent protection.) *8		
	OVERVOLTAGE PROTECTION[V] *8	56 - 60	168 - 180	
	DC_OK LAMP	LED (Green)		
	ALARM LAMP	LED (Amber)		
REMOTE ON/OFF		Provided		
ISOLATION	INPUT-OUTPUT-AUX-RC-WRN-PG	AC3,000V 1minute, Cutoff current = 100mA, DC500V 50MΩ min (At room temperature)		
	INPUT-FG	AC2,000V 1minute, Cutoff current = 100mA, DC500V 50MΩ min (At room temperature)		
	OUTPUT-AUX-RC-WRN-PG-FG	AC500V 1minute, Cutoff current = 100mA, DC500V 50MΩ min (At room temperature)		
	OUTPUT-AUX-RC-WRN-PG	AC100V 1minute, Cutoff current = 100mA, DC100V 50MΩ min (At room temperature)		
ENVIRONMENT	OPERATING TEMP., HUMID. AND ALTITUDE	-10 to +60°C (Output derating is required), 20 - 90%RH (Non condensing), 3,000m (10,000 feet) max		
	STORAGE TEMP., HUMID. AND ALTITUDE	-20 to +75°C, 20 - 90%RH (Non condensing), 9,000m (30,000 feet) max		
	VIBRATION	10 - 55Hz, 19.6m/s ² (2G), 3minutes period, 60minutes each along X, Y and Z axis		
	IMPACT	196.1m/s ² (20G), 11ms, once each along X, Y and Z axis		
SAFETY AND NOISE REGULATIONS	AGENCY APPROVALS	UL60950-1, C-UL (CSA60950-1), EN60950-1		
	CONDUCTED NOISE	Complies with FCC Part15-A, CISPR32-A, EN55011-A, EN55032-A, VCCI-A		
	HARMONIC ATTENUATOR	Complies with IEC61000-3-12		
OTHERS	CASE SIZE/WEIGHT *9	388 X 43 X 475mm [15.28 X 1.69 X 18.70 inches] (W X H X D) / 11kg max		
	COOLING METHOD	Forced cooling (internal fan)		

*1 AUX output power is not included.

*2 The current of input surge to a built-in noise filter (0.2ms or less) is excluded.

*3 Measured by 500MHz oscilloscope.

Ripple and ripple noise is measured on measuring board with capacitor of 22μF within 150mm from the output terminal.

*4 Drift is the change in DC output for an eight hour period after a half-hour warm-up at 25°C, with the input voltage held constant at the rated input/output.

*5 Can't be used above the rated output current and the rated output power.

*6 When the output voltage is adjusted to higher than 49.92V and the load factor is over 70% of the rated current, if the load current changes quickly (< 200msec), the output voltage drops approximately 5V below the setting voltage.

*7 When the output voltage is adjusted to higher than 149.82V and the load factor is over 70% of the rated current, if the load current changes quickly (<200msec), the output voltage drops approximately 15V below the setting voltage.

*8 Output voltage recovers from protection by shutting down the input voltage and waiting more than 10 seconds then turning on AC input again, or turning off the output voltage by remote control.

*9 Case size contains neither the terminal blocks, connector and screw.

* To meet the specifications, do not operate over-loaded condition.

* A sound may occur from power supply at peak loading.

Block diagram

●FETA7000T-48

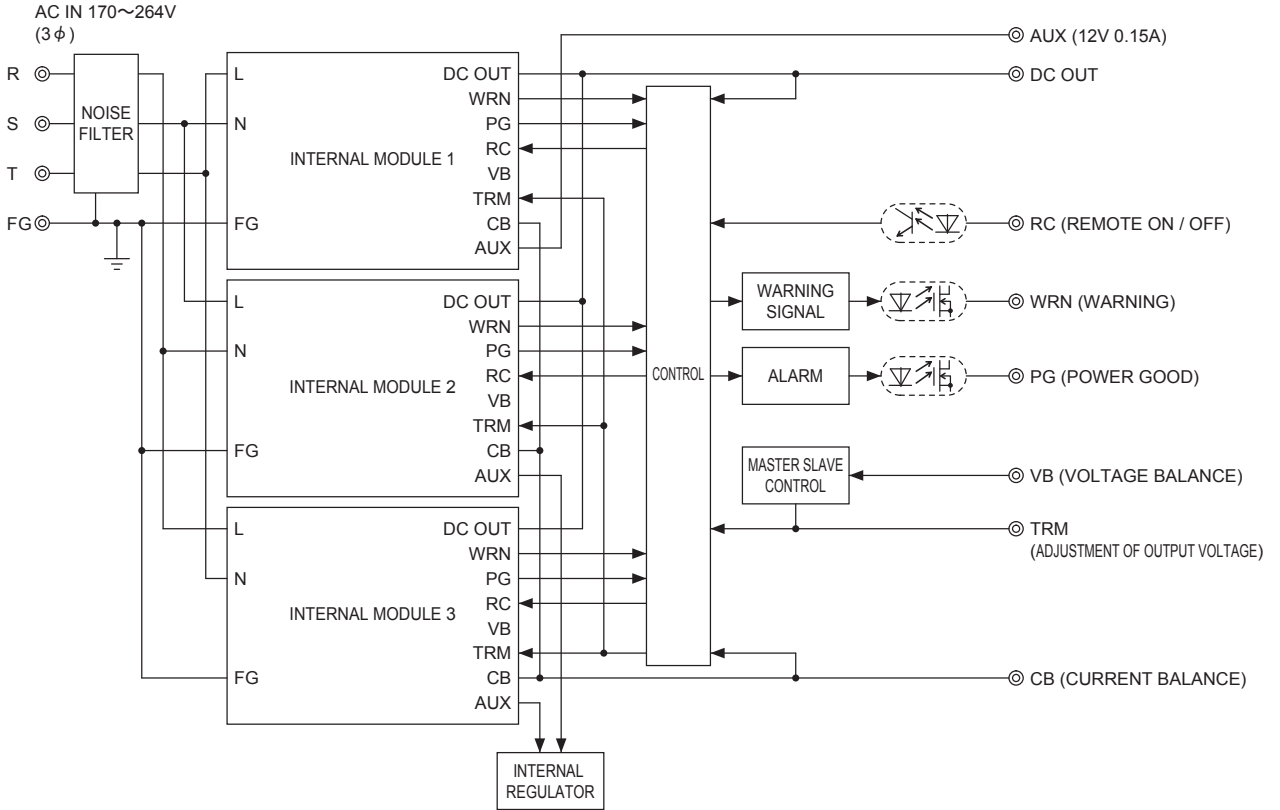

●FETA7000T-144

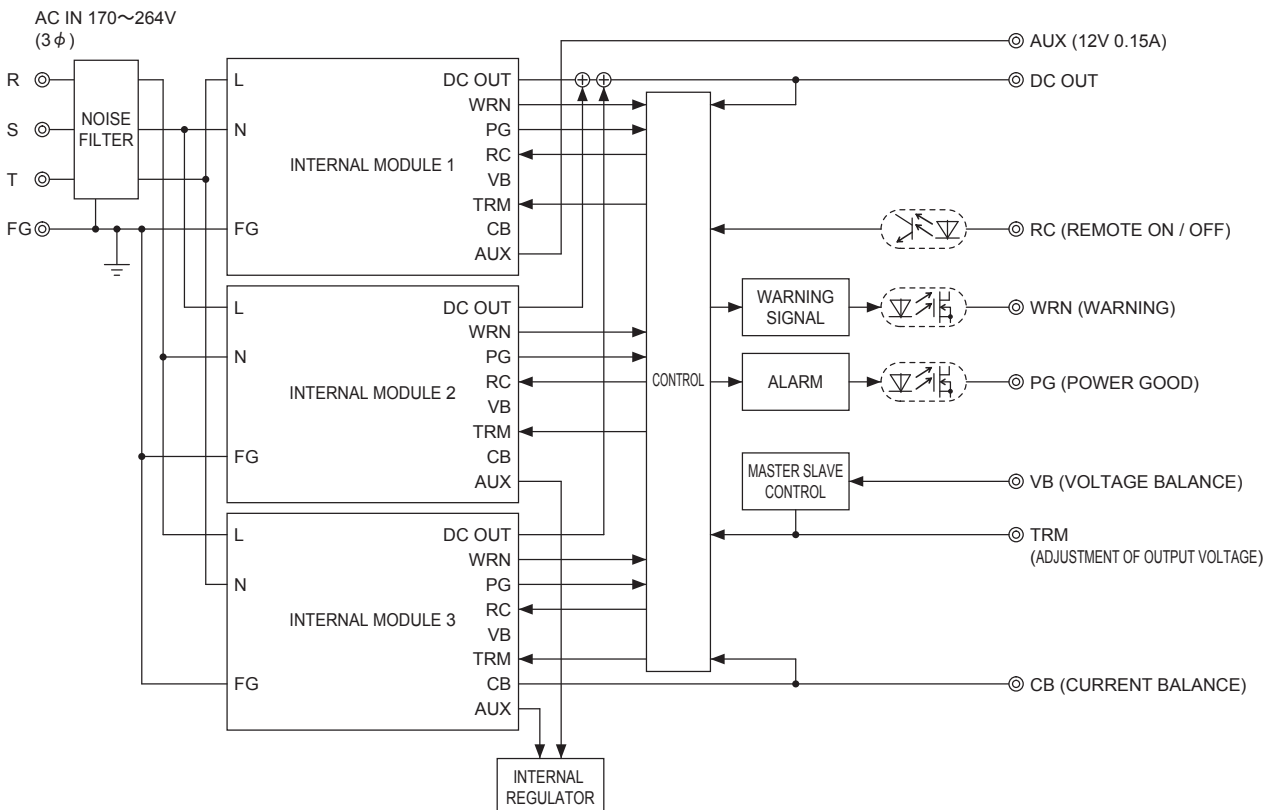

Block diagram of internal module

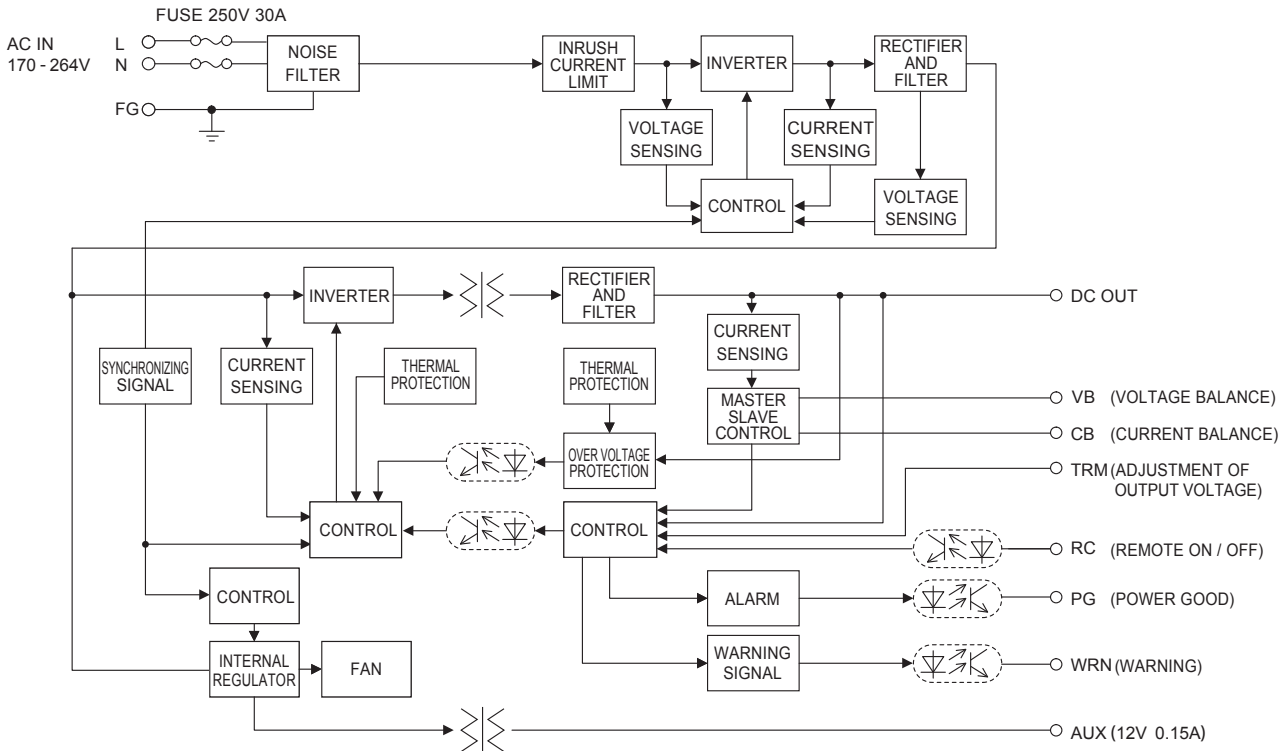

External view

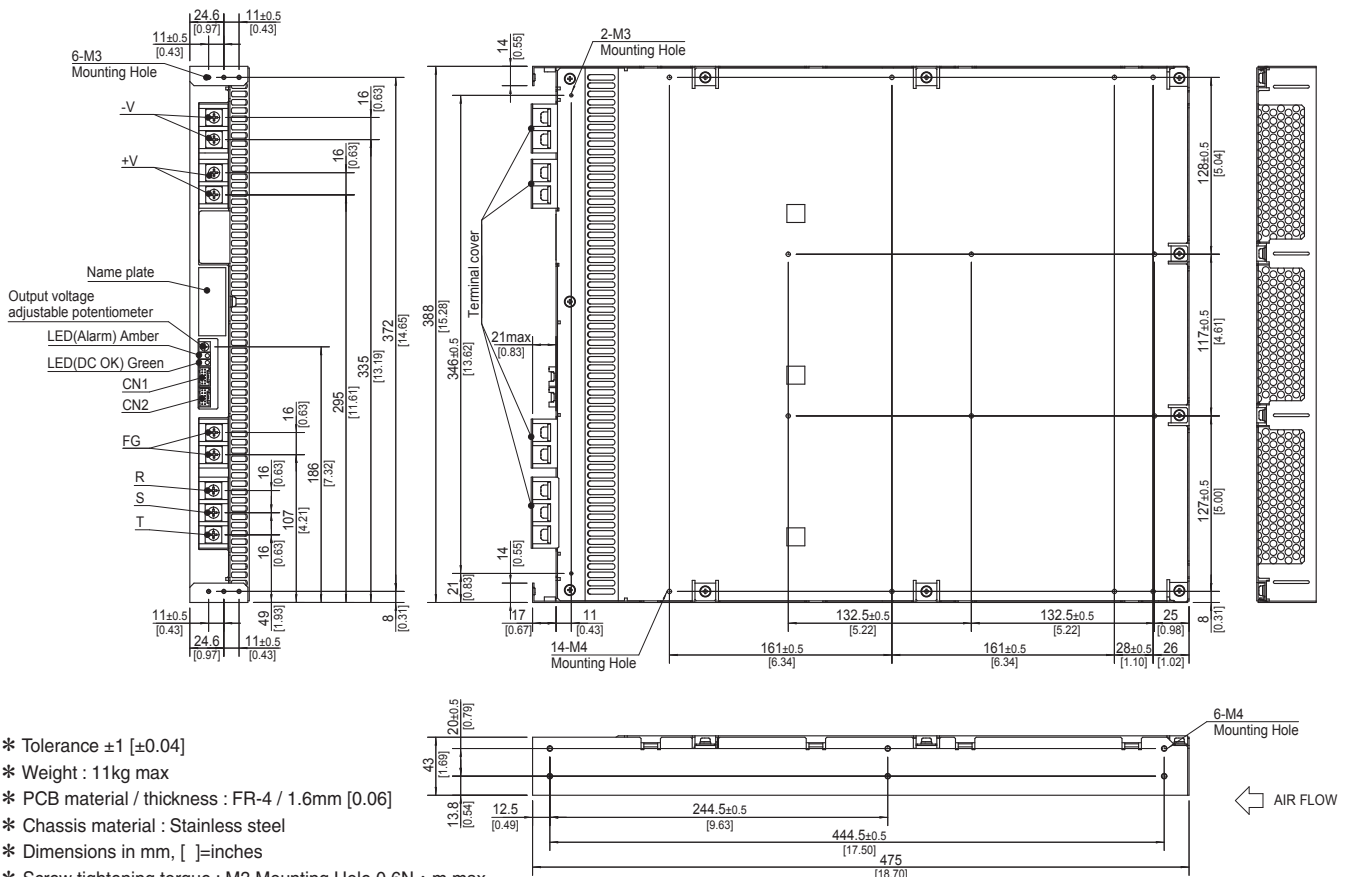

- * Tolerance ± 1 [± 0.04]
- * Weight : 11kg max
- * PCB material / thickness : FR-4 / 1.6mm [0.06]
- * Chassis material : Stainless steel
- * Dimensions in mm, []=inches
- * Screw tightening torque : M3 Mounting Hole 0.6N · m max
M4 Mounting Hole 1.2N · m max
M5 Input terminal 3.0N · m max
- * Please connect safety ground to FG terminal on the unit.

